

120-1 2-arm universal puller "VARIO" with spring-loaded end lock



DESCRIPTION

The 2-arm universal puller "VARIO" with spring-loaded drop safety device is used to pull off bearings, gears and washers in all common sizes for craftsmen, workshops and industry. It can be used to loosen any component that sits on a shaft and is freely accessible from the outside. Equipped with robust, always parallel puller legs, the puller ensures particularly safe, non-destructive dismantling for both external and internal pulling out. The drop guard prevents the puller legs from slipping off the crossbar.

RANGE OF APPLICATION

For pulling off bearings, gear wheels and discs

BENEFIT

- Drop guard prevents the puller legs from slipping off the crossbar
- Pressing down the drop guard guarantees a particularly fast turning of the puller legs
- Application also with eccentric components due to free-moving trigger hooks sliding on the crosshead
- Variable adjustment to any span between xx - xxx mm
- Safe positioning of the spindle due to rotatable spindle tip both on smooth surfaces and for centring (Switch Technology)
- Optionally convertible from an external extractor to an internal extractor by reversing the extractor legs
- Anti-slip device on the spindle head for safe working with spanners
- Spindle run-out to protect the thread

OPERATION

- Apply the puller leg to the part to be pulled off from the outside
- Push the claws under the part
- Pull the spindle manually to fix it
- Move the hexagon on the spindle head with a ratchet or a combination spanner until the component is released

APPLICATION IMAGE



DETAIL IMAGE



MASTER DATA

GTIN	4021176918551
Country of origin	DE
Material	Tool steel
Series	120
Net weight [kg]	1,06 kg
Gross weight [kg]	
Package contents	1 piece
Packaging Act	PAP 21

SPARE PARTS

- 120-1-T
- 0-100-P_2 Pulling legs (pair)
- 614135_Mechanical pressure spindle

2-arm universal puller "VARIO" with spring-loaded end lock

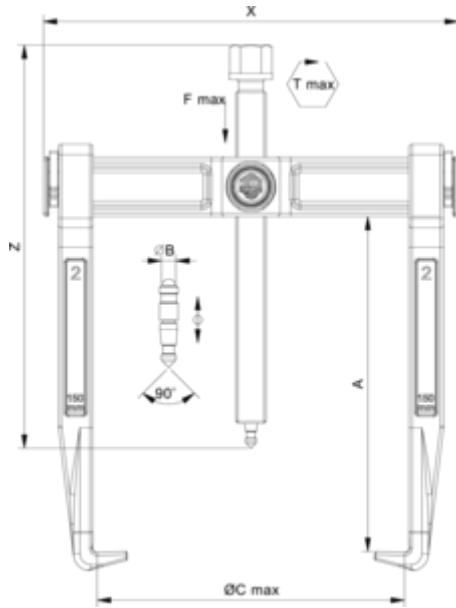

Abbreviation	Attribut	Wert
X	Total width [mm]	150 mm
Y	Total depth [mm]	35 mm
Z	Total height [mm]	155 mm
A	Clamping depth outside pull-off [mm]	100 mm
S1	Width across flats [mm]	17 mm
S2	Width across flats [mm]	
Cmin	Span outside pull-off (min.) [mm]	20 mm
Cmax	Span outside pull-off (max.) [mm]	100 mm
A1	Clamping depth of external pull-off A1 [mm]	
A2	Clamping depth outside pull-off A2 [mm]	
A3	Clamping depth external pull-off A3 [mm]	
A5	Clamping depth external peel-off A5 [mm]	
A4	Clamping depth outside pull-off A4 [mm]	
K	Hook root thickness at the tip (claw thickness K) [mm]	4,5 mm
J	Hook base width (claw width J) [mm]	21 mm
O	Hook base depth usable (claw depth usable O) [mm]	15 mm
H	Total hook root depth (total claw depth H) [mm]	30 mm
L	Total claw thickness (L+1mm) (claw distance to base) [mm]	9 mm
Emin	Span inside pull-out (min.) [mm]	100 mm
Emax	Span inside pull-out (max.) [mm]	130 mm
Tmax	Max. torque [Nm]	
Fmax	Max. tractive force [t]	3 t
Fmax	Max. tensile force [kN]	30 kN

Abbreviation	Attribut	Wert
X	Total width [mm]	150 mm
Y	Total depth [mm]	35 mm
Z	Total height [mm]	155 mm
A	Clamping depth outside pull-off [mm]	100 mm
S1	Width across flats [mm]	17 mm
S2	Width across flats [mm]	
Cmin	Span outside pull-off (min.) [mm]	20 mm
Cmax	Span outside pull-off (max.) [mm]	100 mm
A1	Clamping depth of external pull-off A1 [mm]	
A2	Clamping depth outside pull-off A2 [mm]	
A3	Clamping depth external pull-off A3 [mm]	
A5	Clamping depth external peel-off A5 [mm]	
A4	Clamping depth outside pull-off A4 [mm]	
K	Hook root thickness at the tip (claw thickness K) [mm]	4,5 mm
J	Hook base width (claw width J) [mm]	21 mm
O	Hook base depth usable (claw depth usable O) [mm]	15 mm
H	Total hook root depth (total claw depth H) [mm]	30 mm
L	Total claw thickness (L+1mm) (claw distance to base) [mm]	9 mm
Emin	Span inside pull-out (min.) [mm]	100 mm
Emax	Span inside pull-out (max.) [mm]	130 mm
Tmax	Max. torque [Nm]	
Fmax	Max. tractive force [t]	3 t
Fmax	Max. tensile force [kN]	30 kN

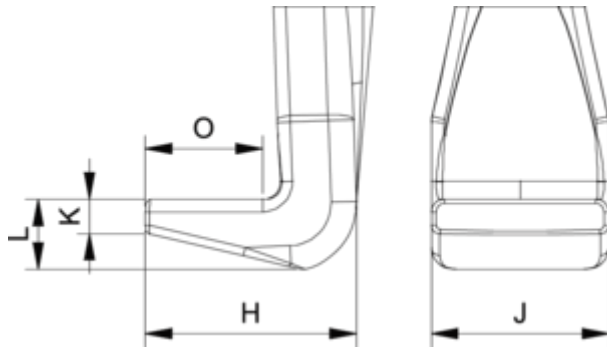

Abbreviation	Attribut	Wert
X	Total width [mm]	150 mm
Y	Total depth [mm]	35 mm
Z	Total height [mm]	155 mm
A	Clamping depth outside pull-off [mm]	100 mm
S1	Width across flats [mm]	17 mm
S2	Width across flats [mm]	
Cmin	Span outside pull-off (min.) [mm]	20 mm
Cmax	Span outside pull-off (max.) [mm]	100 mm
A1	Clamping depth of external pull-off A1 [mm]	
A2	Clamping depth outside pull-off A2 [mm]	
A3	Clamping depth external pull-off A3 [mm]	
A5	Clamping depth external peel-off A5 [mm]	
A4	Clamping depth outside pull-off A4 [mm]	
K	Hook root thickness at the tip (claw thickness K) [mm]	4,5 mm
J	Hook base width (claw width J) [mm]	21 mm
O	Hook base depth usable (claw depth usable O) [mm]	15 mm
H	Total hook root depth (total claw depth H) [mm]	30 mm
L	Total claw thickness (L+1mm) (claw distance to base) [mm]	9 mm
Emin	Span inside pull-out (min.) [mm]	100 mm
Emax	Span inside pull-out (max.) [mm]	130 mm
Tmax	Max. torque [Nm]	
Fmax	Max. tractive force [t]	3 t
Fmax	Max. tensile force [kN]	30 kN